

INSTRUCTIONS FOR BOWSER PRR A-5 0-4-0 Loco and Tender

The builder should study the instructions and drawings to attain a working knowledge of proper procedure. Assembly work should be in sequence outlined in this manual to assure proper construction. We have included some extra parts in case you misplace or drop them on the floor.

If for reasons beyond our control, any shortage or faulty part is found, write directly to the manufacturer, including name of your dealer and date of purchase. Return any defective parts for exchange.

DO NOT RUN THE MECHANISM OR ENGINE UPSIDE DOWN.

TOOLS

This is a builders kit, you will need a few tools. You will find use for the following: small hammer, several assorted pattern files, jewelers screwdriver (a set is convenient), a 6" flat file with a fairly fine cut, knife, pliers, flush cut nippers like Mascot #413 and tweezers.

BEFORE PAINTING YOUR MODEL OR DETAIL THE BOILER, WE RECOMMEND THAT YOU BUILD THE COMPLETE MECHANISM ATTACH THE UNDECORATED BODY AND THOROUGHLY TRACK TEST IT.

STEP #1

Clean flash from edges of parts and assemble drivers to frame.

Subkit 100573

FULL SIZE



256041

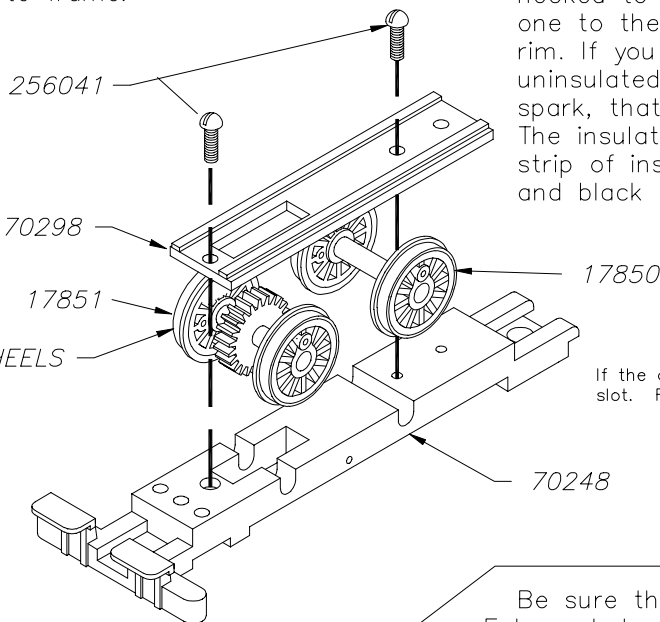

INSULATED WHEELS THIS SIDE

Identify which wheel of each set of drivers is insulated. With two wires hooked to your power pack, touch one to the axle and one to a wheel rim. If you cause a spark, that is the uninsulated wheel. If there is no spark, that is the insulated wheel. The insulated wheel has a thin gray strip of insulation between the tire and black wheel center.

If the driver does not roll in the axle slot. File the slot with a round file

Be sure the wheels spin freely. Enlarge holes in side rods with a round file to eliminate any binds. Mechanism must roll freely before proceeding any further. Oil lightly.

STEP #2

Assemble side rods to mechanism.

Subkit 100571

FULL SIZE

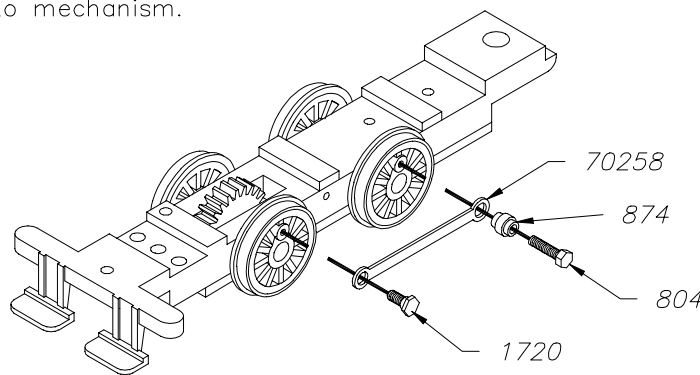
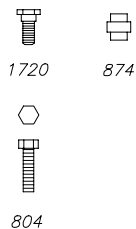

# STEP #4

Assemble crosshead guides to cylinders and hangers.  
 Assemble crossheads to main rods.  
 Crossheads must slide freely on guide rods.

Subkit 100571, 100575

FULL SIZE



904



256071



806

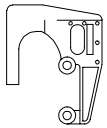

90472  
Left Valve Gear Hanger

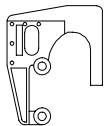

90473  
Right valve gear hanger

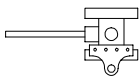

90474 Left

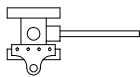

90475 Right

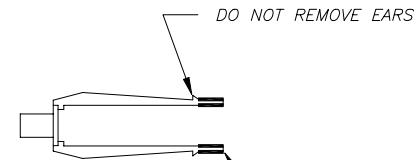
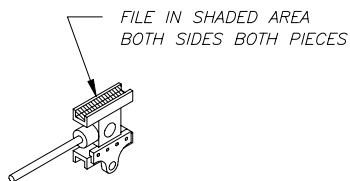
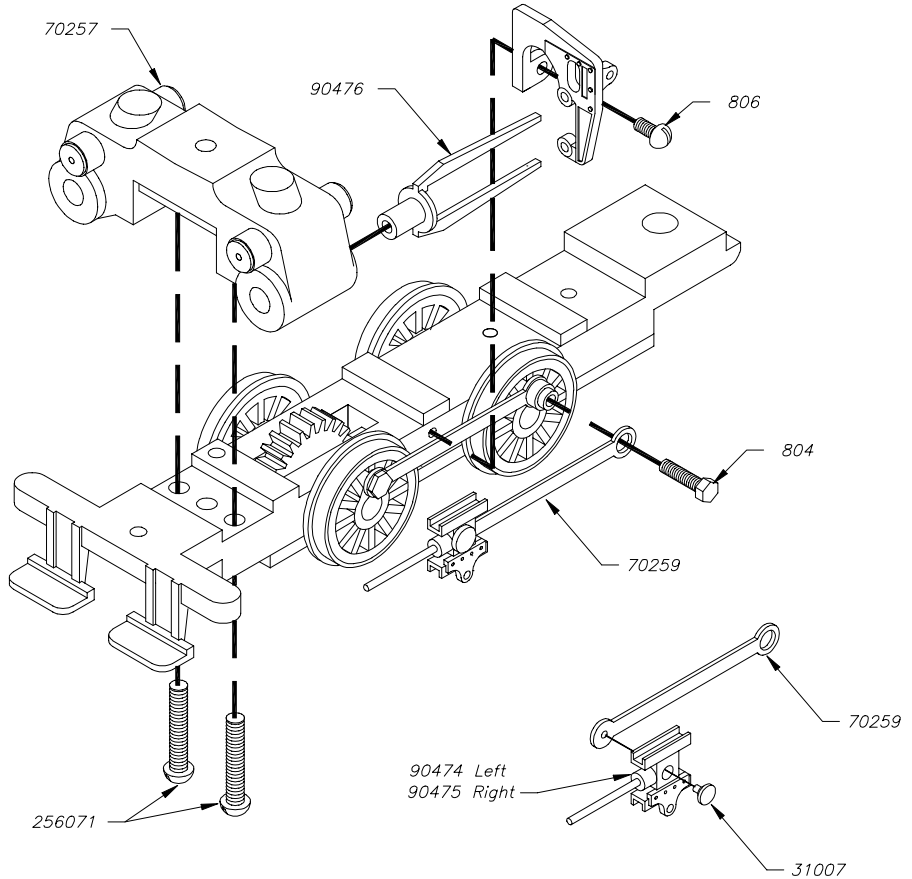

NOTE: CROSSHEAD MUST MOVE FREELY ON MAIN ROD.

FILE UNTIL CROSSHEAD GUIDE #90476 FITS INTO HANGER

# STEP #3

PARTS IDENTIFICATION LIST  
 SUBKIT #100571 & #100575  
 SHOWN FULL SIZE

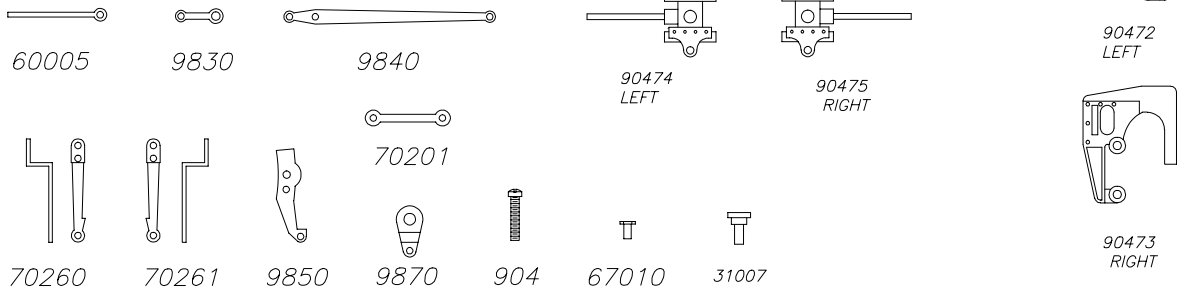

SET RIVETOOL WITH CENTER POINT  
 IN HOLE IN END OF RIVET. TAP WITH  
 LIGHT HAMMER UNTIL RIVET IS  
 PROPERLY FLARED. BE CAREFUL  
 NOT TO MAKE JOINT TOO TIGHT.

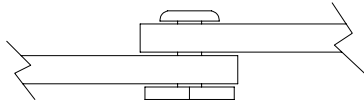

SIDE VIEW OF RIVET  
 SHOWN 10X SIZE  
 NOTE CLEARANCE

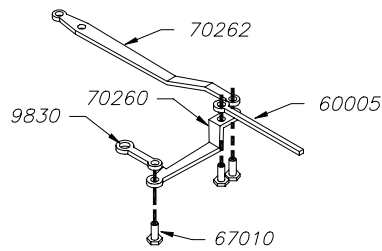

STEP 1    LEFT SIDE FRONT UNIT

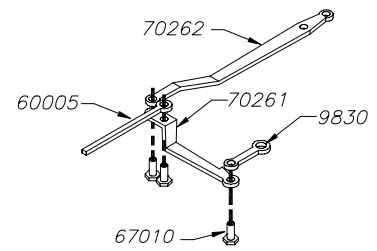

STEP 2    RIGHT SIDE FRONT UNIT

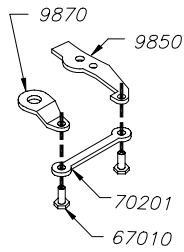

STEP 3    LEFT SIDE REAR UNIT

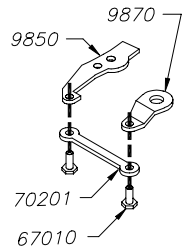

STEP 4    RIGHT SIDE REAR UNIT

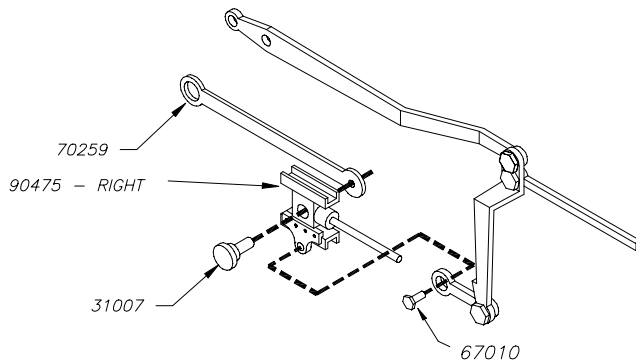
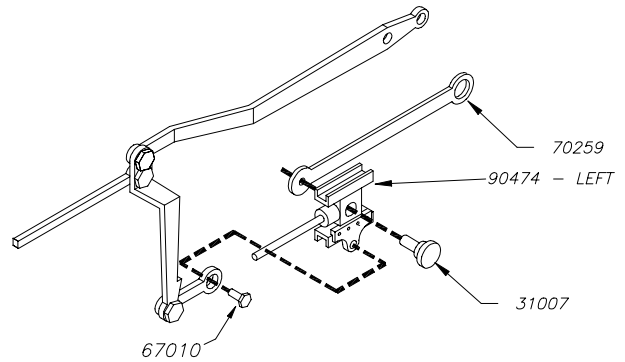

i: \A5\100570-3 10/07/98 07:27

# STEP #5

Install valve gear.  
Time valves as shown in diagram below.  
Mechanism must run without any binds.

Left side shown being installed  
Right side ready to install.

Subkit 100571

FULL SIZE

-  804
-  904
-  67010

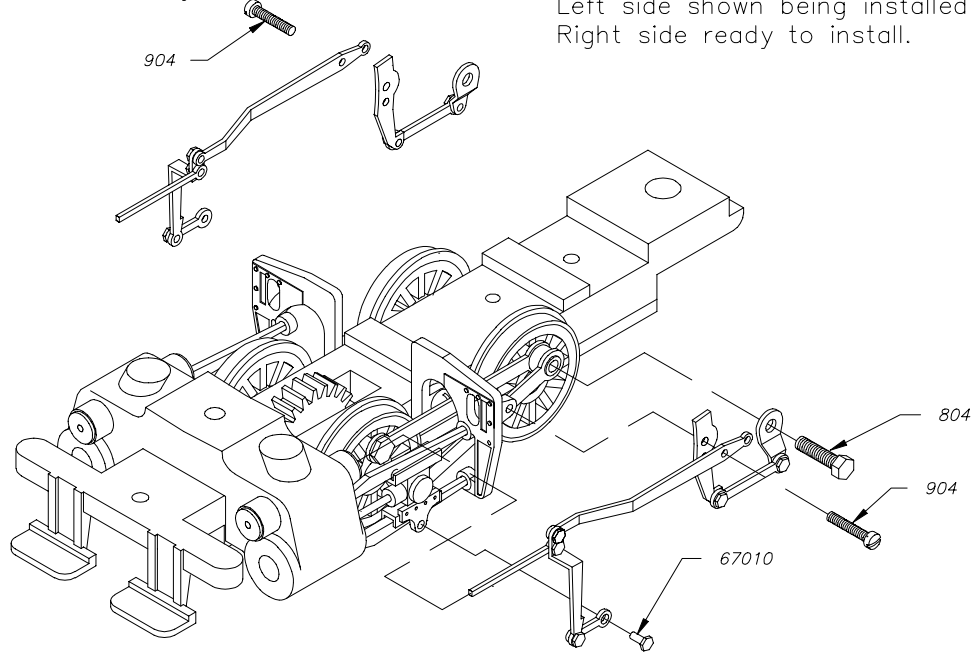

Enlarged view of valve gear installed.

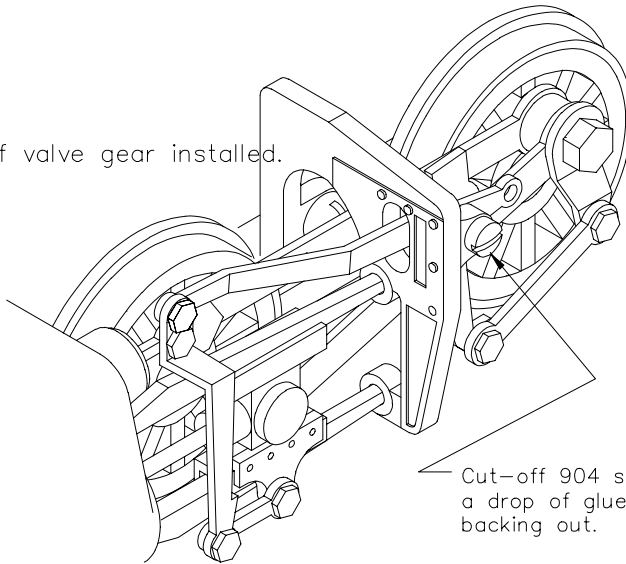

Cut-off 904 screw after assembly and put a drop of glue on threads to keep it from backing out.

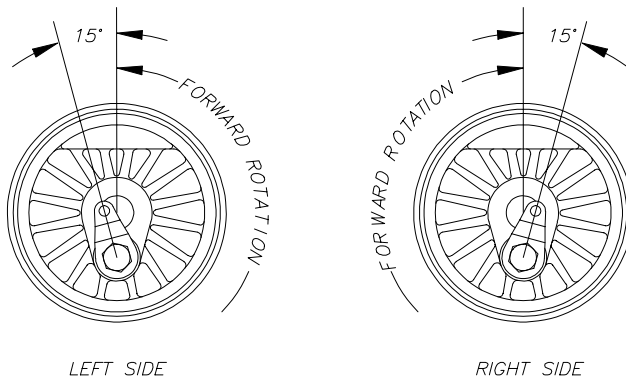

STEP #6  
Install motor.

Subkit 100573  
FULL SIZE



256061



256021

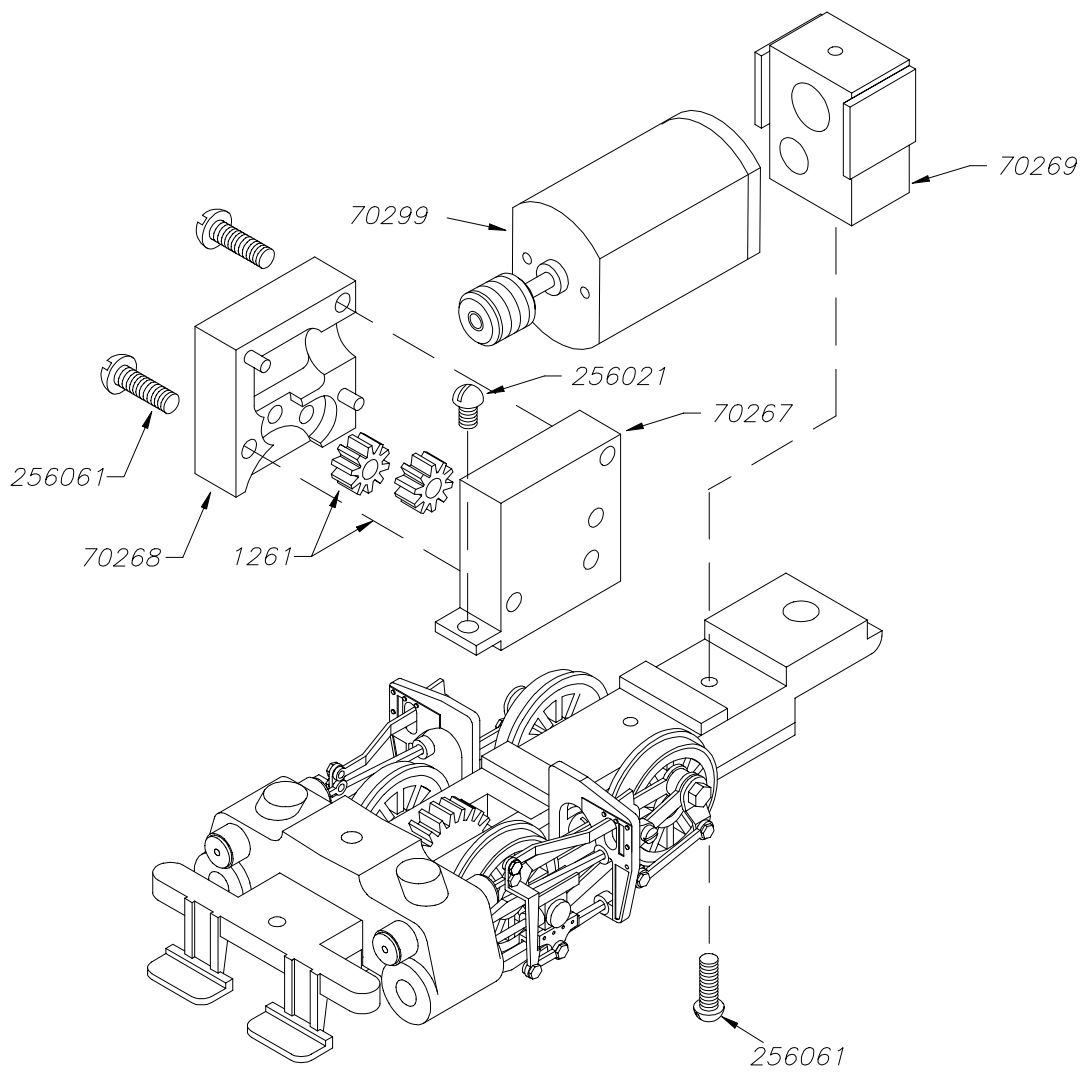

## STEP #7

Install pilot & train control box.

Subkit 100573

FULL SIZE

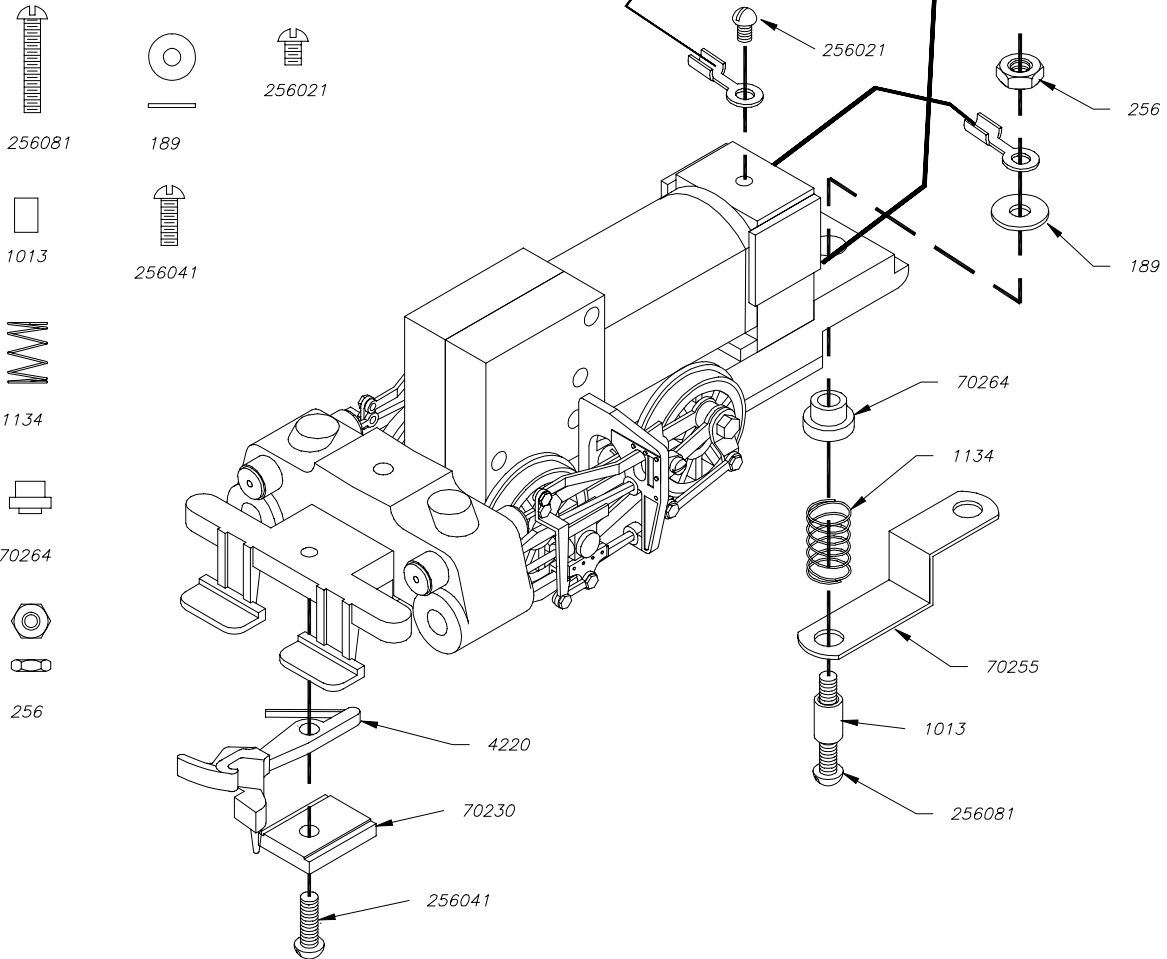

## STEP #8

Hook wires from power pack to drawbar and frame. Run for several hours in each direction.

# STEP #9

Detail boiler  
Do not paint boiler until after thoroughly track testing engine.

Subkit 100576

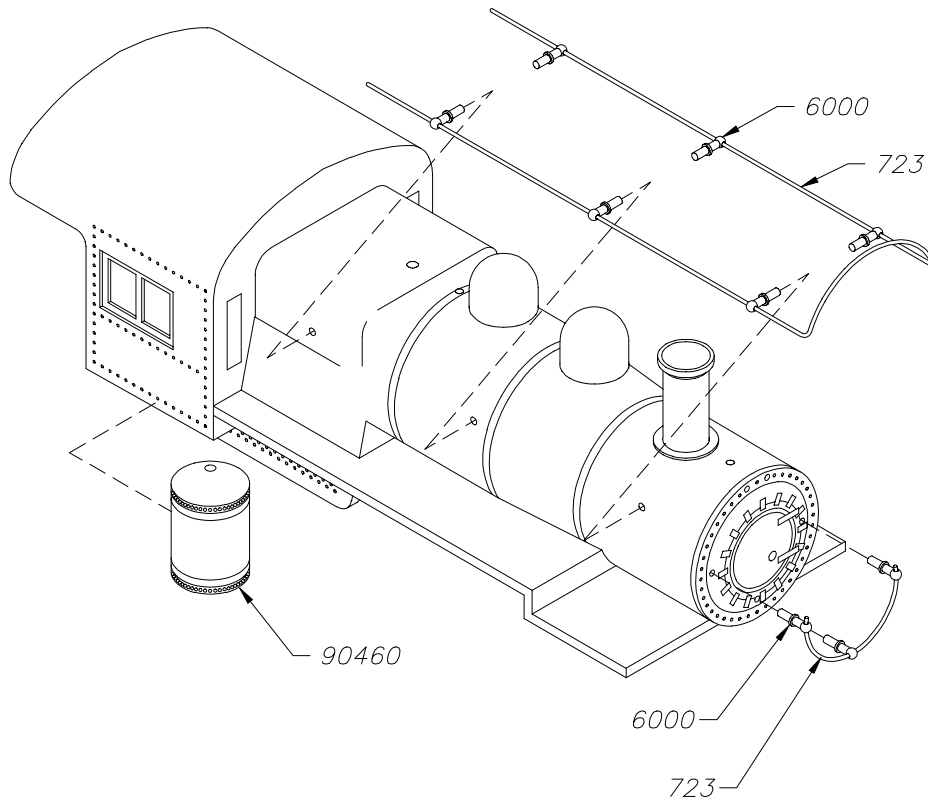
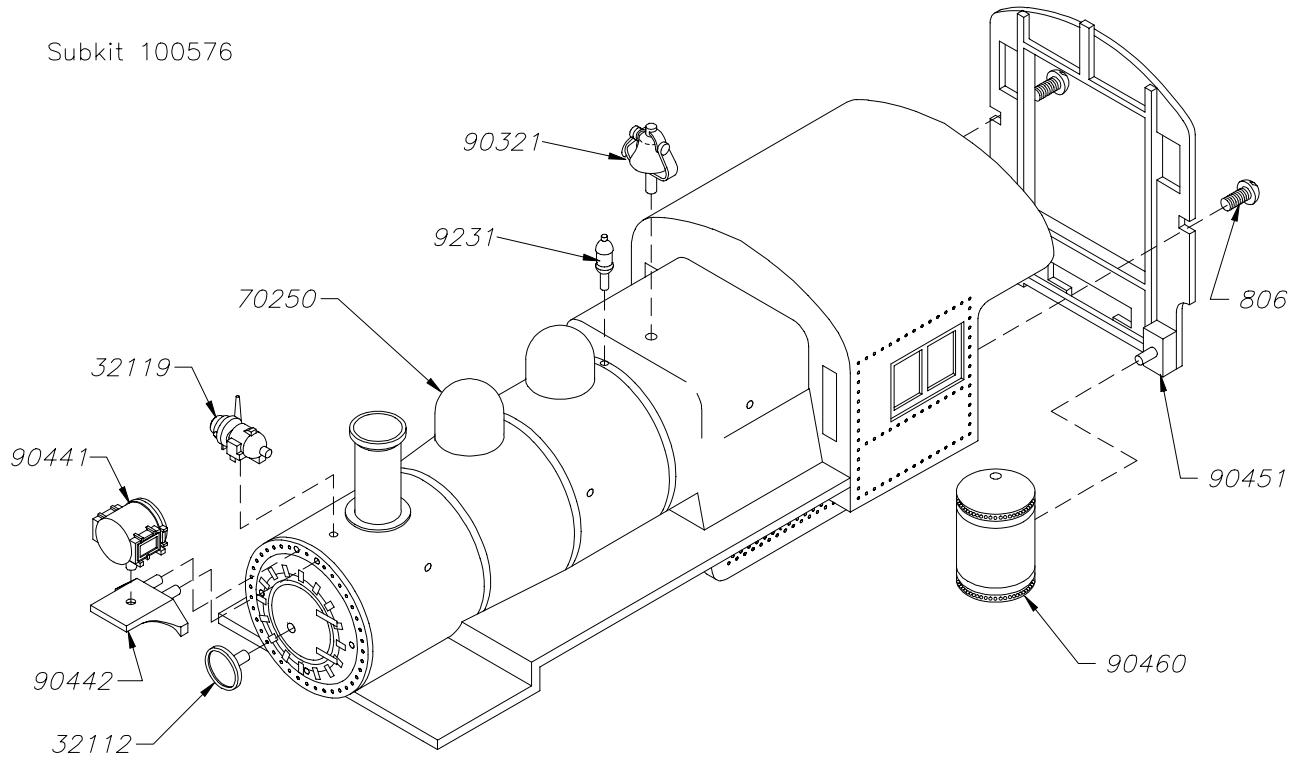

# STEP #10

Assemble boiler to mechanism

Subkit 100573

FULL SIZE



256101

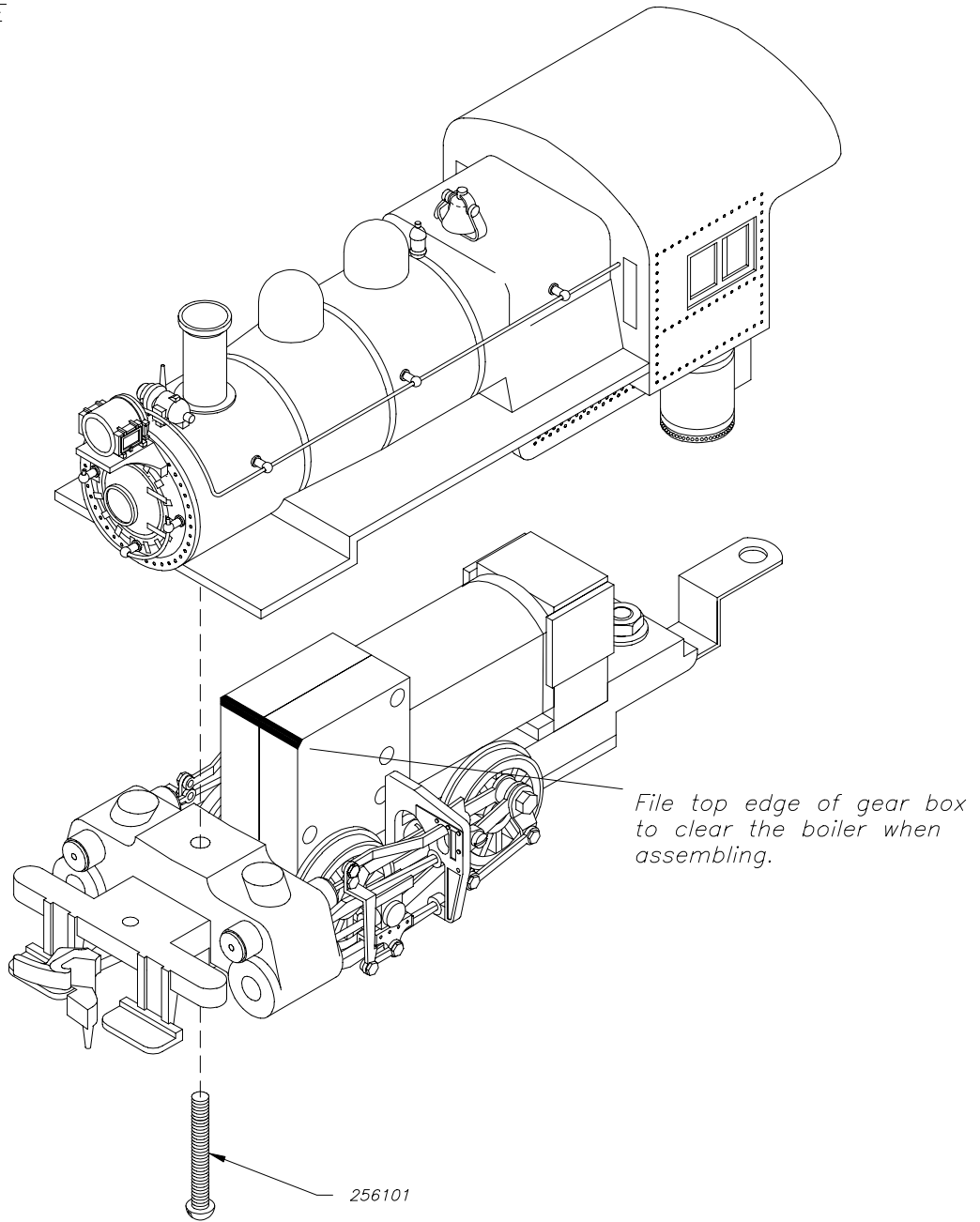



# STEP #11

Assemble tender

Subkit #40002

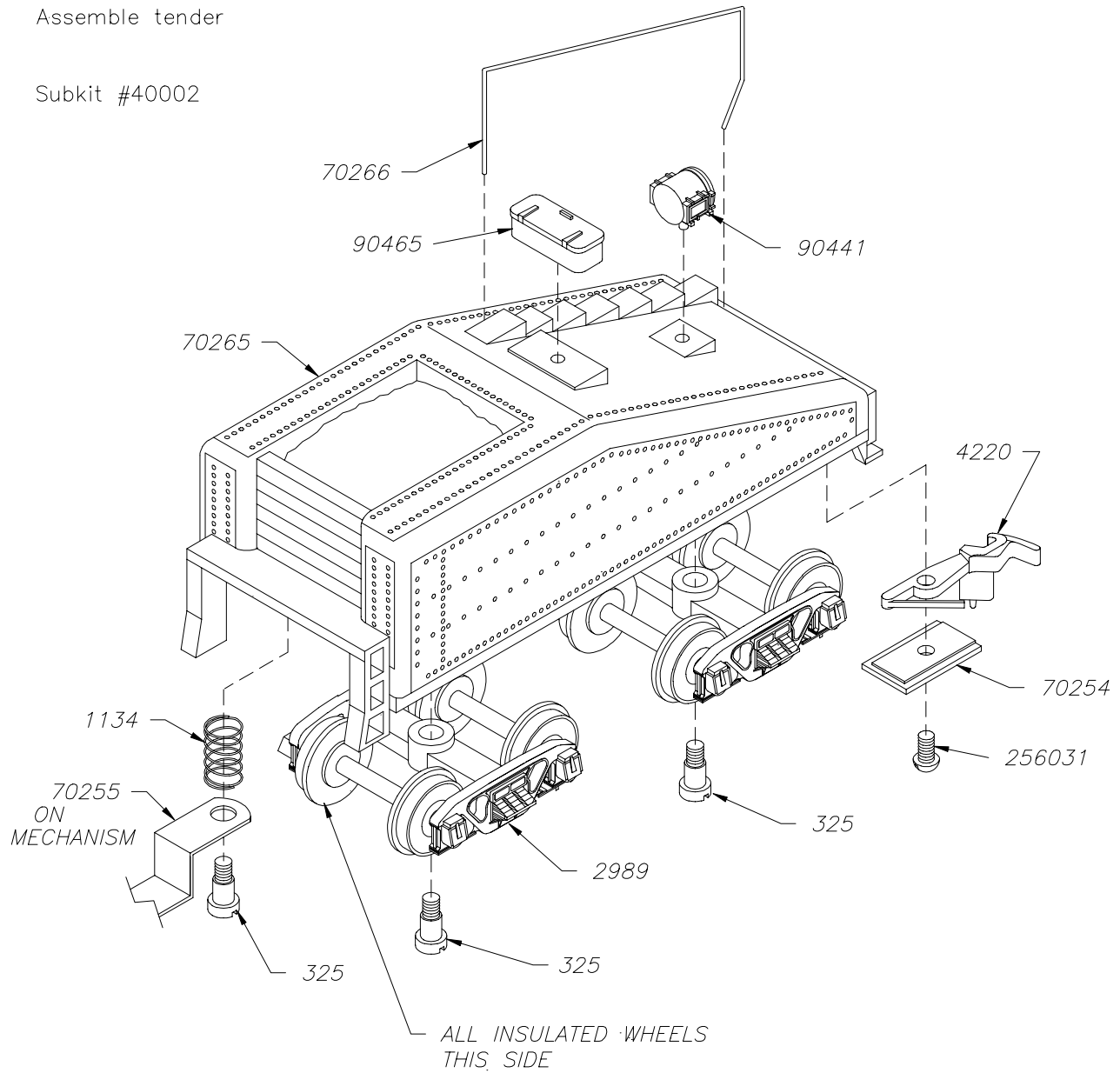

# STEP #12

Assemble tender to engine. Test run.

Disassemble engine and tender.

Paint reassemble and ENJOY.

# Miscellaneous Building Tips

## TIP 1: Painting Metal

You may want to superdetail your loco before painting.

We suggest that you do not paint your loco until it is thoroughly track tested as disassembly and handling generally ruins a paint job. Take your locomotive apart so that the various parts may be painted without getting paint on moving parts.

Valve gear, side rods, bearings, pony truck, etc. will not operate properly if paint gets into the joints of moving parts.

Parts to be painted should be degreased with a solvent like paint thinner and pickled in acetic acid solution (vinegar) or oxalic acid solution (5%) for a few minutes before applying paint.

**DO NOT USE THIS VINEGAR FOR COOKING OR EATING.**

Rinse with clean water. Do not handle the surfaces to

be painted. CAUTION: Do not immerse wheels, underframe or cover plate in acid solution or cleaners. Brush cleaner and acid solutions on metal frames of lead and trailing trucks and on underframe surfaces to be painted (NOT ON WHEELS, AXLES OR BEARING SLOTS). Drivers are pre-blackened and can be touched up, after removing flash, without using cleaner or acid. I recommend a glossy paint be used (PRR locos were painted Brunswick Green). Apply a smooth, uniform coat of good grade model railroad paint. I like to spray paint my models. Work carefully to avoid piling up paint around small details.

Painting exposed surfaces of main frame will add to final appearance of model, but be careful not to get paint in any bearings.

## TIP 2: Hex Head Wrench (Cheap and Easy)

Go to your hardware store and buy Socket Head Cap Screws or Set Screws in many different sizes. They have the hex shape machined in the head and will work for tightening hex head screws.

## TIP 3: Soldering Tips

Wear Eye Protection

First be sure everything is clean.

Put flux on both parts. Hold together and place solder iron at joint. The solder will flow to the hot area. Solder should not form a ball. This indicates the area was not hot enough. To tin your soldering iron so that solder will stick to it.

When cold clean the tip with a file. Put a little flux on tip. Turn on iron and apply solder to the tip as soon as it gets hot.

If this does not work. Clean the tip while hot and dip tip in a drop of flux (while hot) and immediately put solder on tip.

## TIP 4: Cleaning A File When the Grooves Fill

When filing parts, the grooves in a file will fill with the metal you are filing.

This metal can be removed quickly by using a small piece of thin steel (1/16 to 1/8" thick) and sliding the steel on the file in the direction of the grooves. The chips that remain can be removed by sliding a sharp knife in each groove. This may take awhile to clean each groove. I do this only as a last resort. To keep most of the chips from sticking while you file, apply a thin oil to the file before filing.

## TIP 5: Drilling Small Holes

To drill metal with small drills it is best to use powered tools. Dremel tool or a small drill press. Hand drilling with a pin vise will work but is much slower. You must drill straight. Drills do not bend they break. Use a lubricant on the drill. Cutting oil is best, but you can use a bar of Ivory Soap. Put the lube on the drill before starting. I recommend peck drilling.

(Drill about 1 or 2 times the diameter of the drill and remove the drill from the hole. Clean off the chips. Lube the drill and repeat.)

Take your time. It is very important to clean the chips from the flutes of the drill. When the flutes fill with chips the drill will break.

The smaller the drill the more you need to peck drill.

## TIP 6: Tapping a Drilled Hole

First be sure your hole is the proper size.

00-90 Taps #60

0-80 Taps #55

2-56 Tap #49

4-40 Tap #43

These drill sizes are one size larger than the charts.

We feel they work very well for steel, brass and zinc.

You must tap straight. Taps do not bend they break.

Use a lubricant on the tap. Cutting oil is best but you can use a bar of Ivory Soap.

Put the lube on the tap before starting.

Turn in tap to get it started (1 or 2 turns). Back off 1/2 turn. This breaks the chips that form when tapping.

Repeat above. As the hole gets deeper you will have to back off the tap more often. If you are tapping a very deep hole you will have to back off the tap after as little as 1/2 turn